

Artic-raatiovaunu Paluu tulevaisuuteen

Ollipekka Heikkilä 2013



Presidents' Conference Committee



Tyypillinen 1930-luvun raitiovaunu

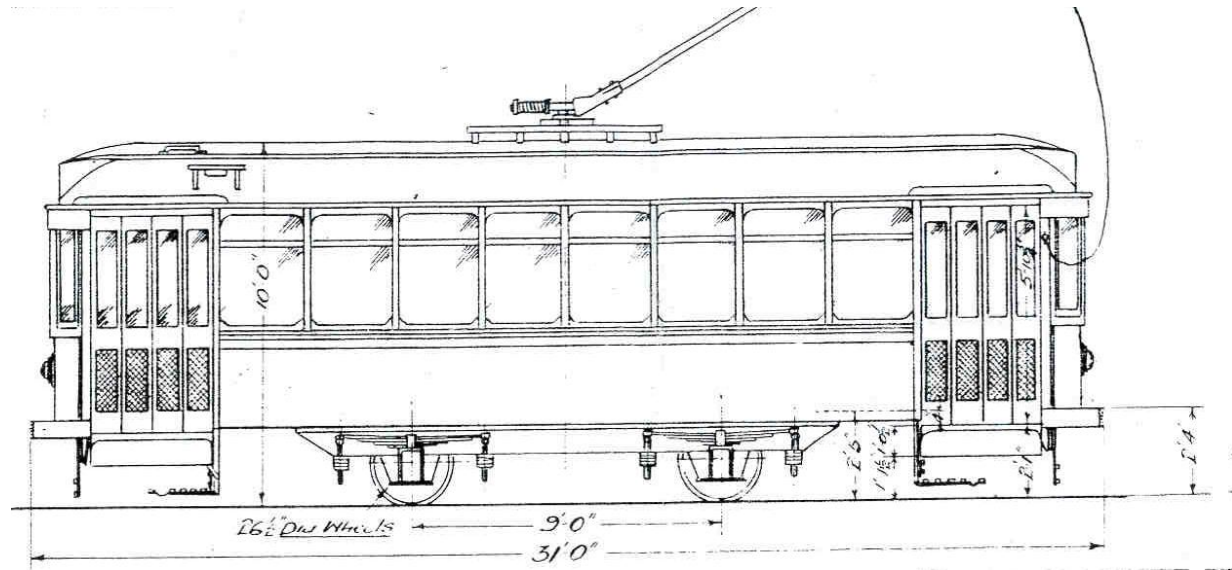

- Melu ja värinä
- Sivuttaissuuntaiset heilahtelut
- Huono lämmitys ja ilmanvaihto
- Suuri kiskojen ja pyörien kulutus
- Vaikea huollettavuus ja suuri huoltotarve
- Korkea elinkaarikustannus

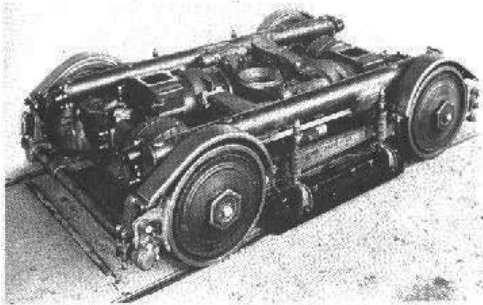
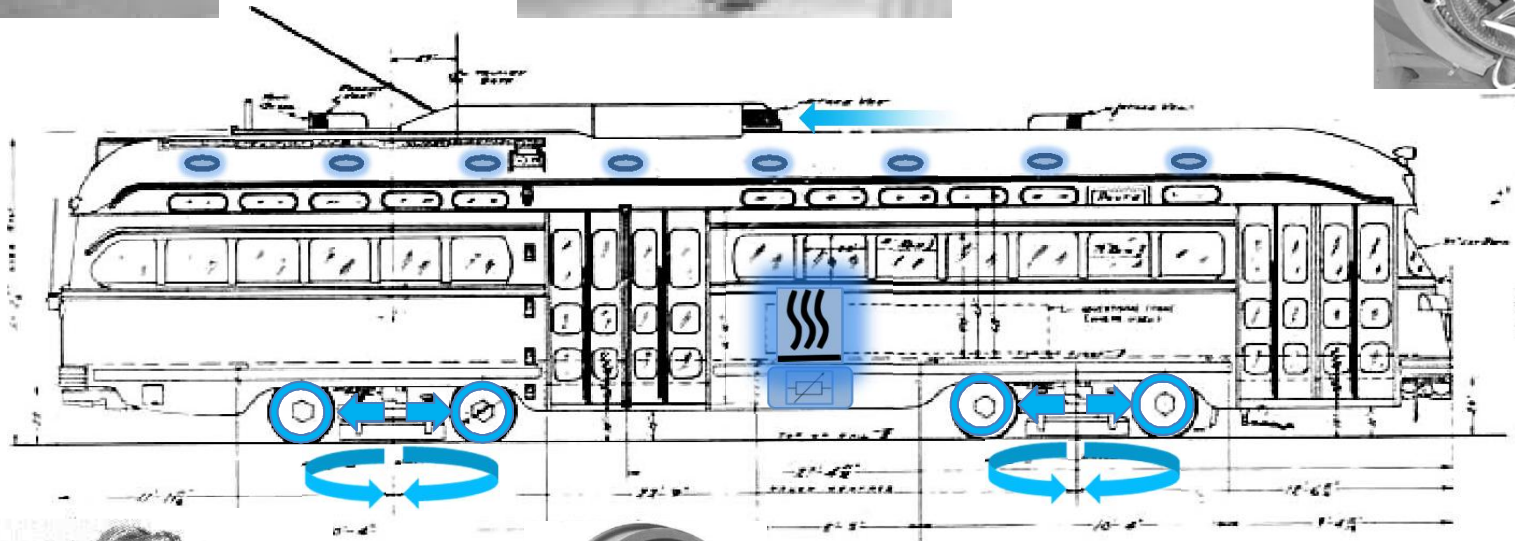
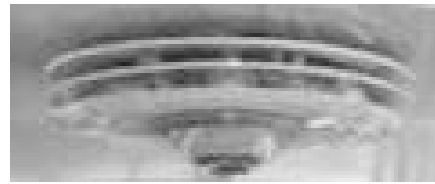
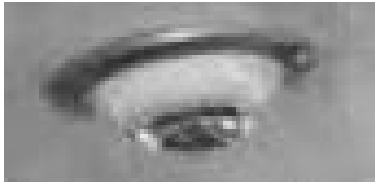

Super-Rivolt WHEELS

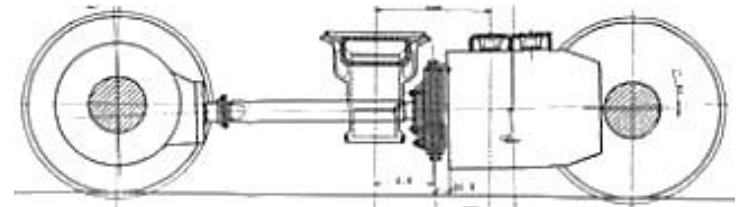

PCC-raatiovaunun valmistus

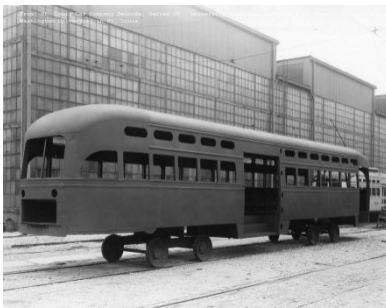

PCC-raitiovaunun lisenssivalmistus





Tyypillinen 2010-luvun raitiovaunu

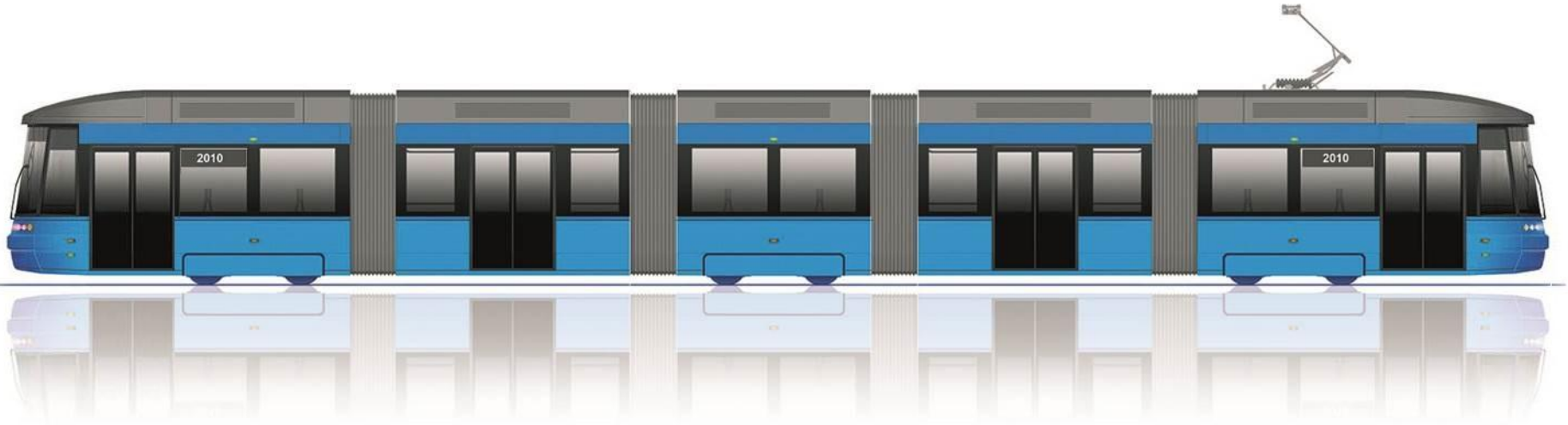

- Melu ja värinä rataherätteen kohdalla
- Sivuttaissuuntaiset heilahtelut
- Lämmityksen suuri energiankulutus
- Suuri kiskojen ja pyörien kulutus
- Huono etenemiskyky erikoisolosuhteissa
- Vaikea huollettavuus ja suuri huoltotarve
- Korkea elinkaarikustannus

Helsinki-vaunun kehitystyö

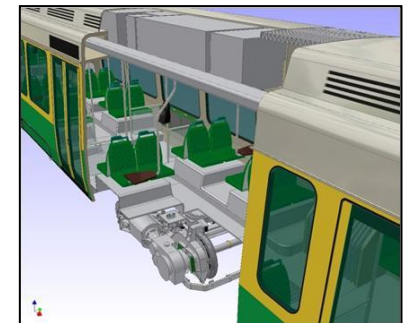
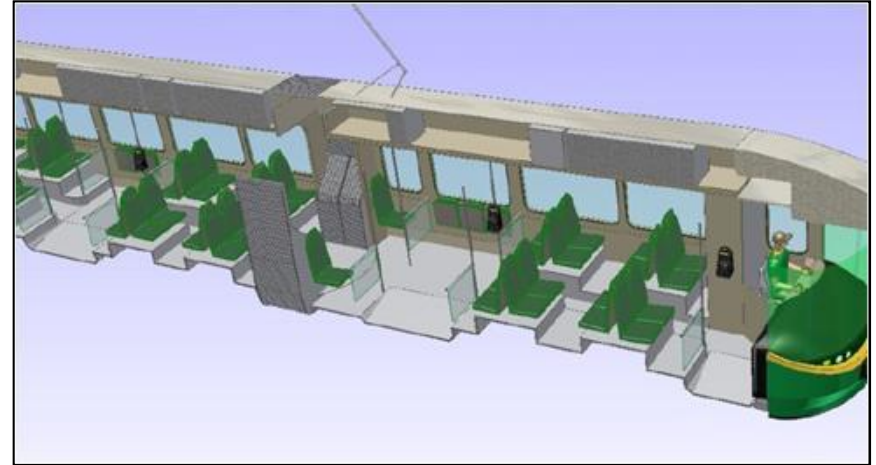
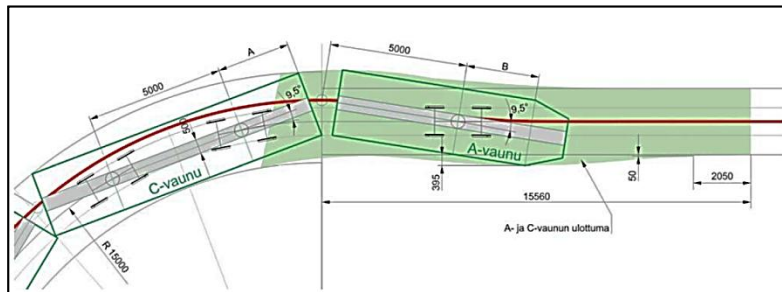
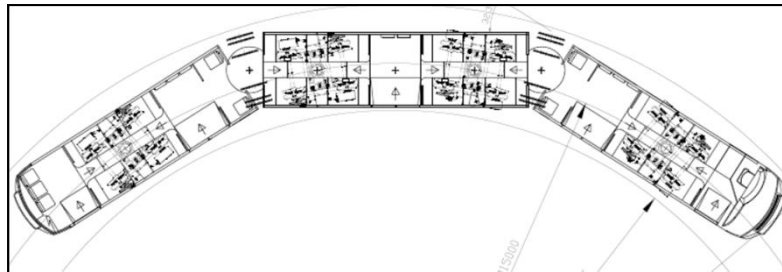
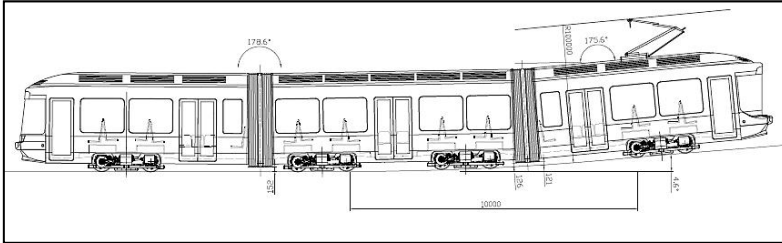

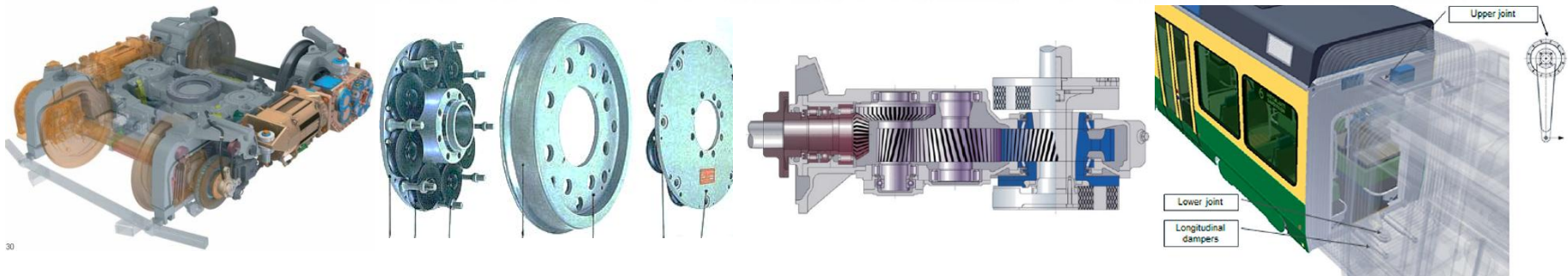
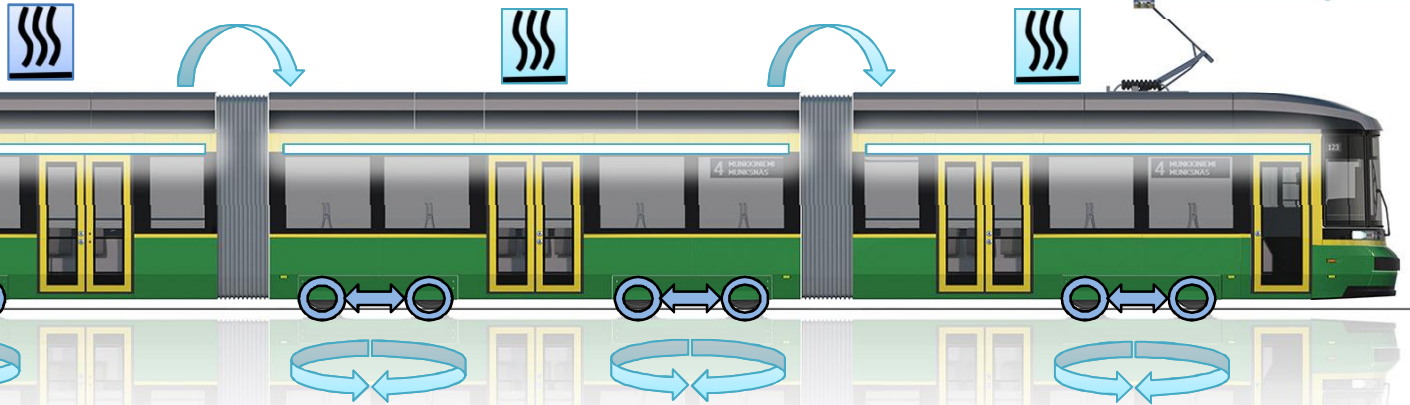

30

TRANSTECH



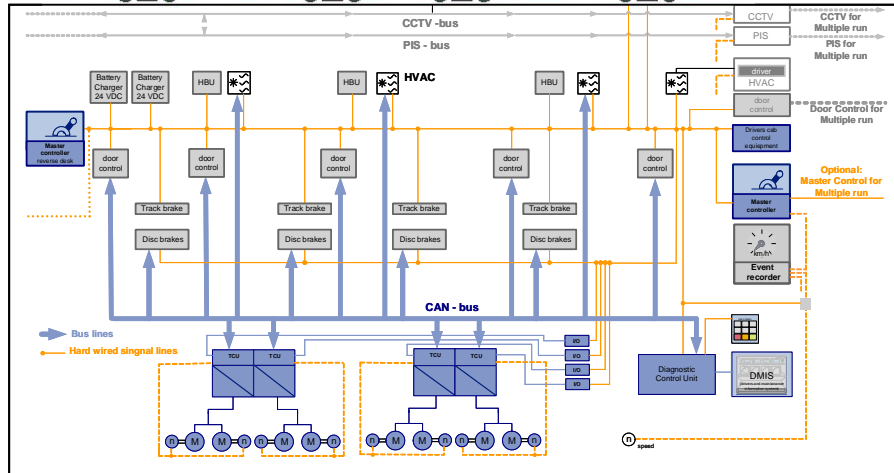
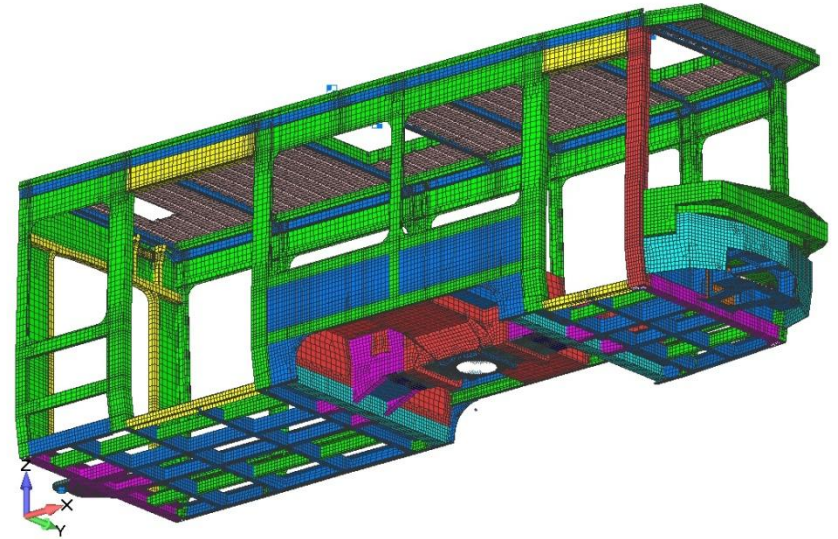
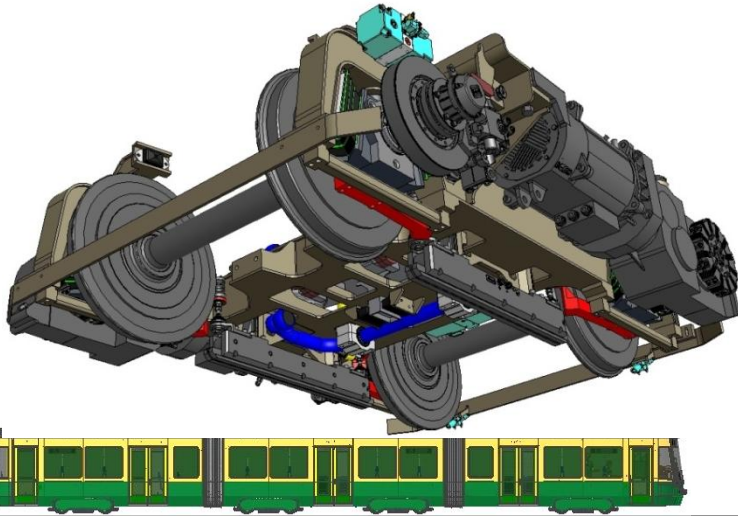

Transtech Artic - muotoiluprosessi

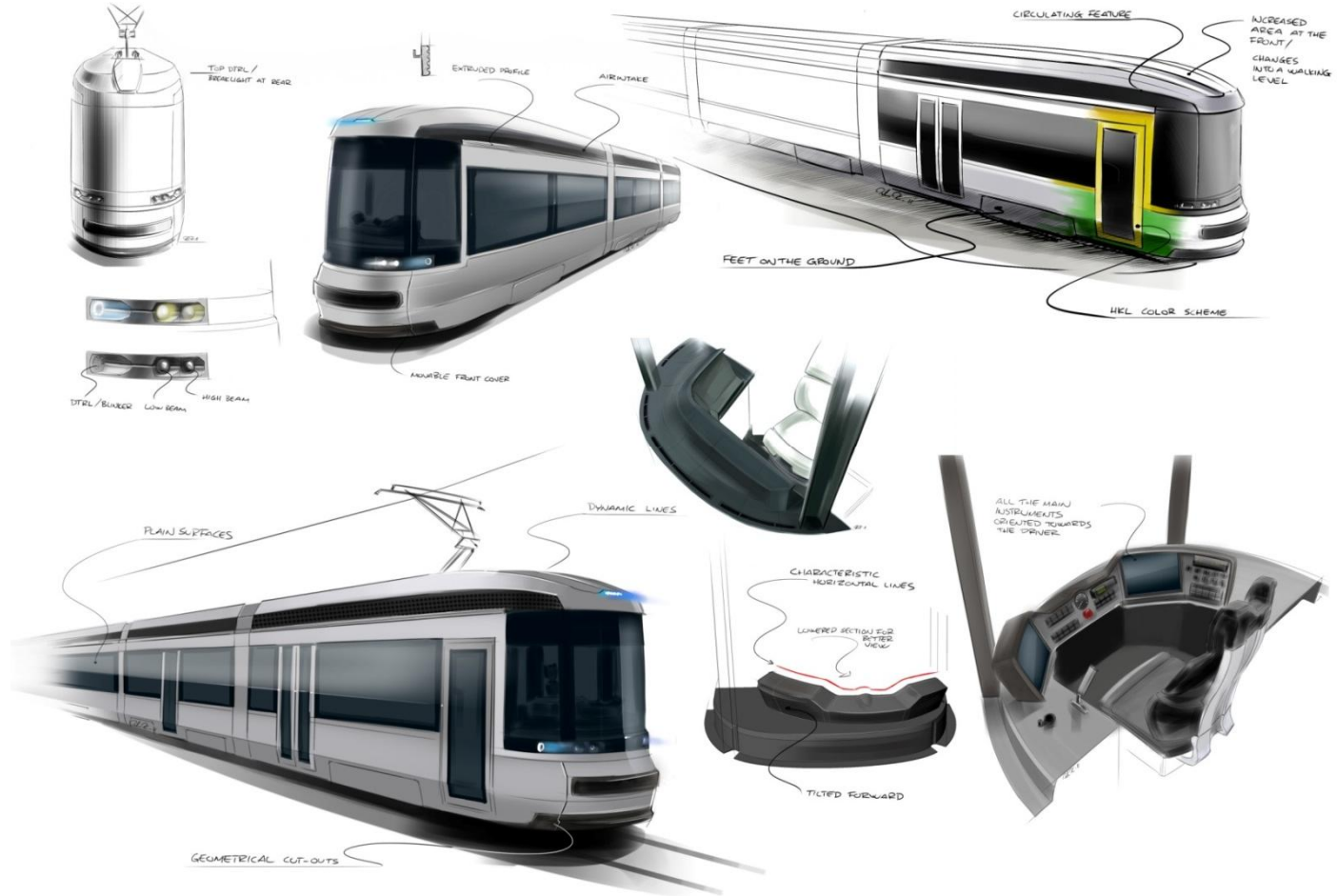

Transtech Artic - mallien valmistus



Transtech Artic - valmistus ja testaus



Transtech Artic - tilankäyttö

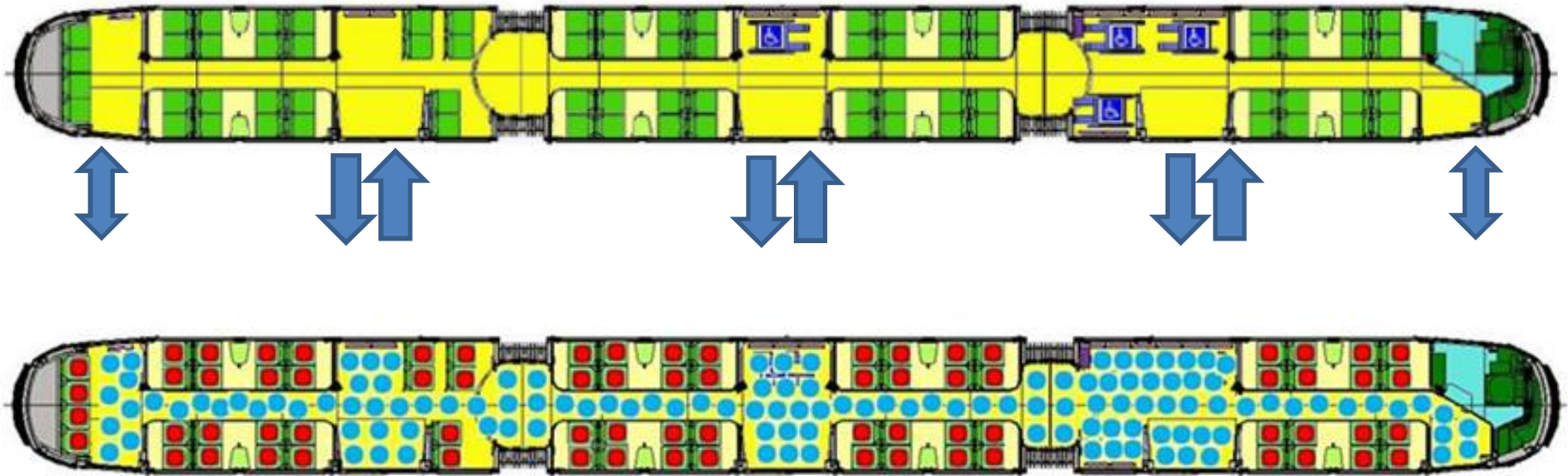

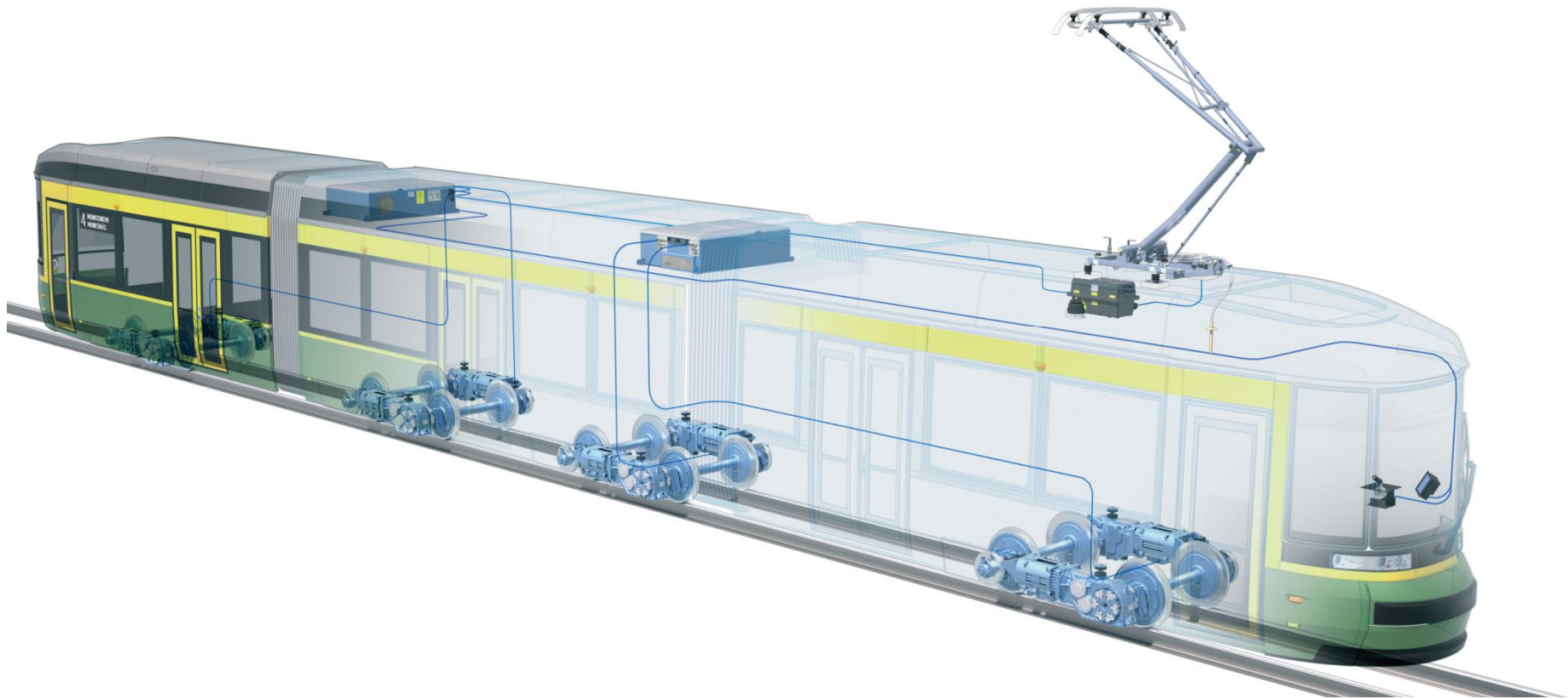

Transtech Artic - kulkuominaisuudet

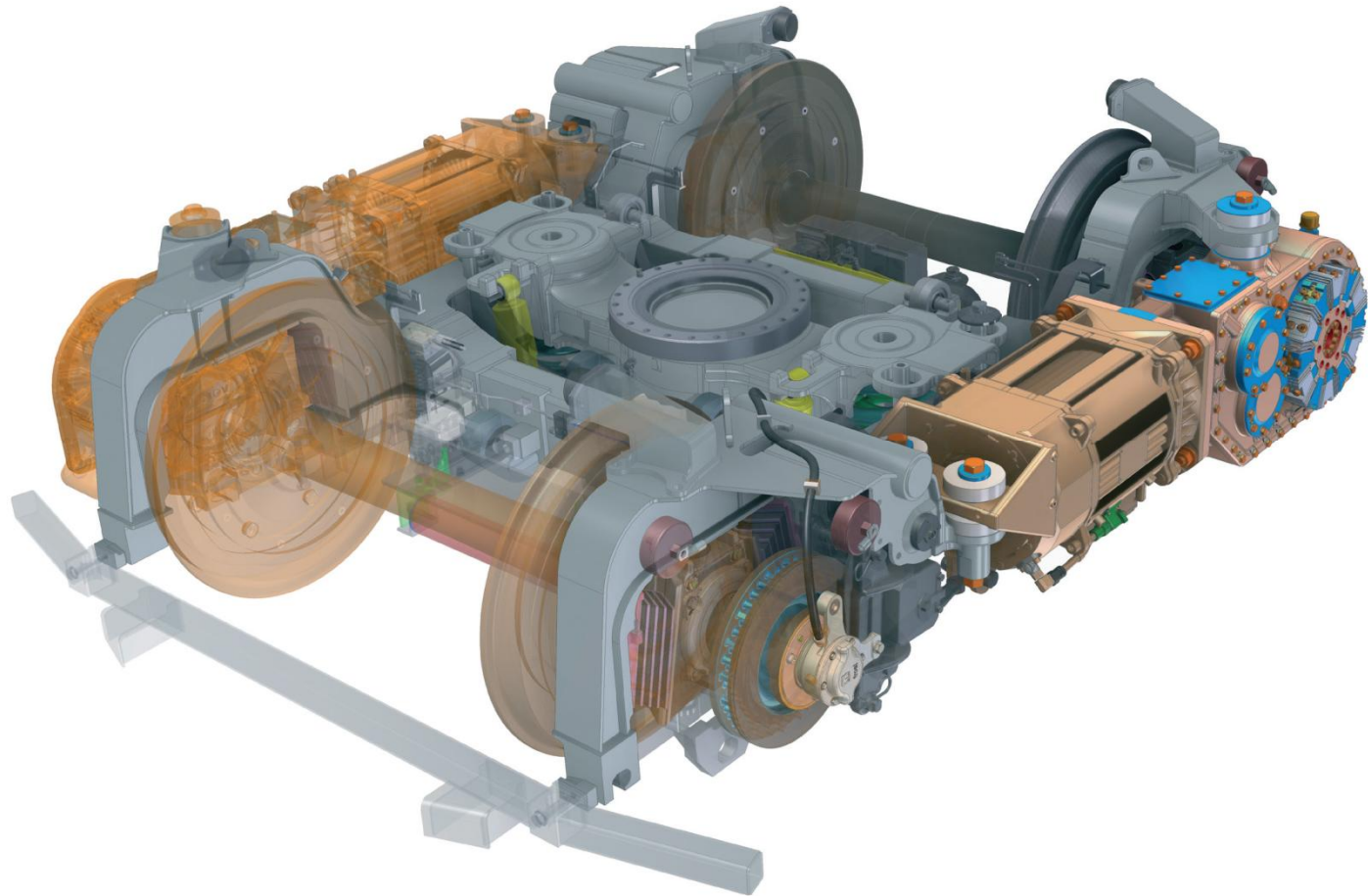

Transtech Artic - elinkaarikustannus

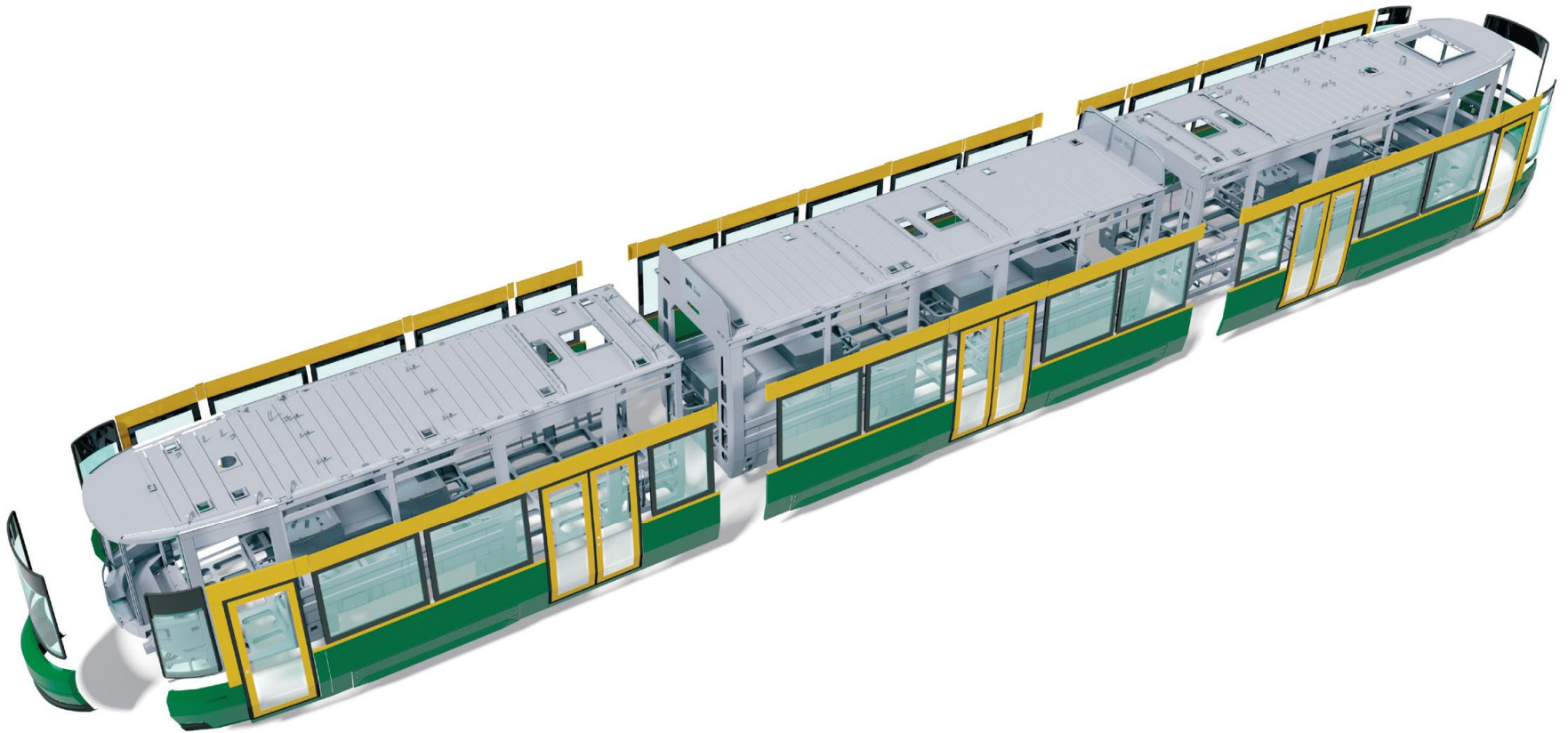

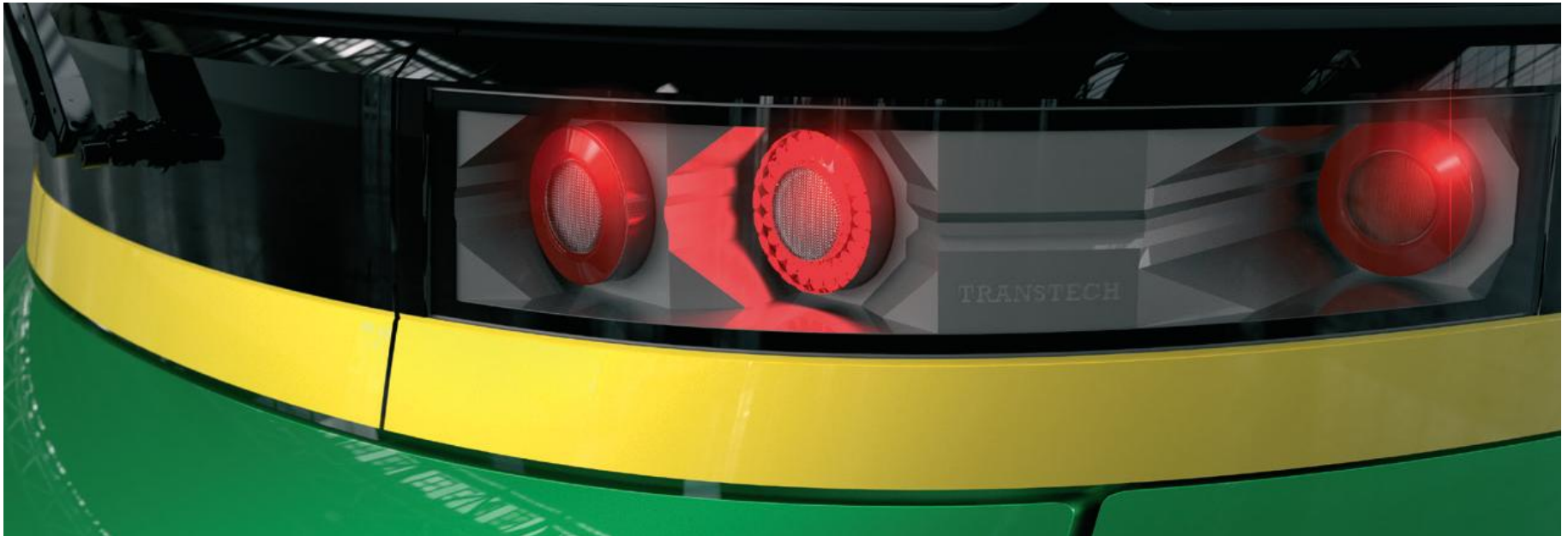

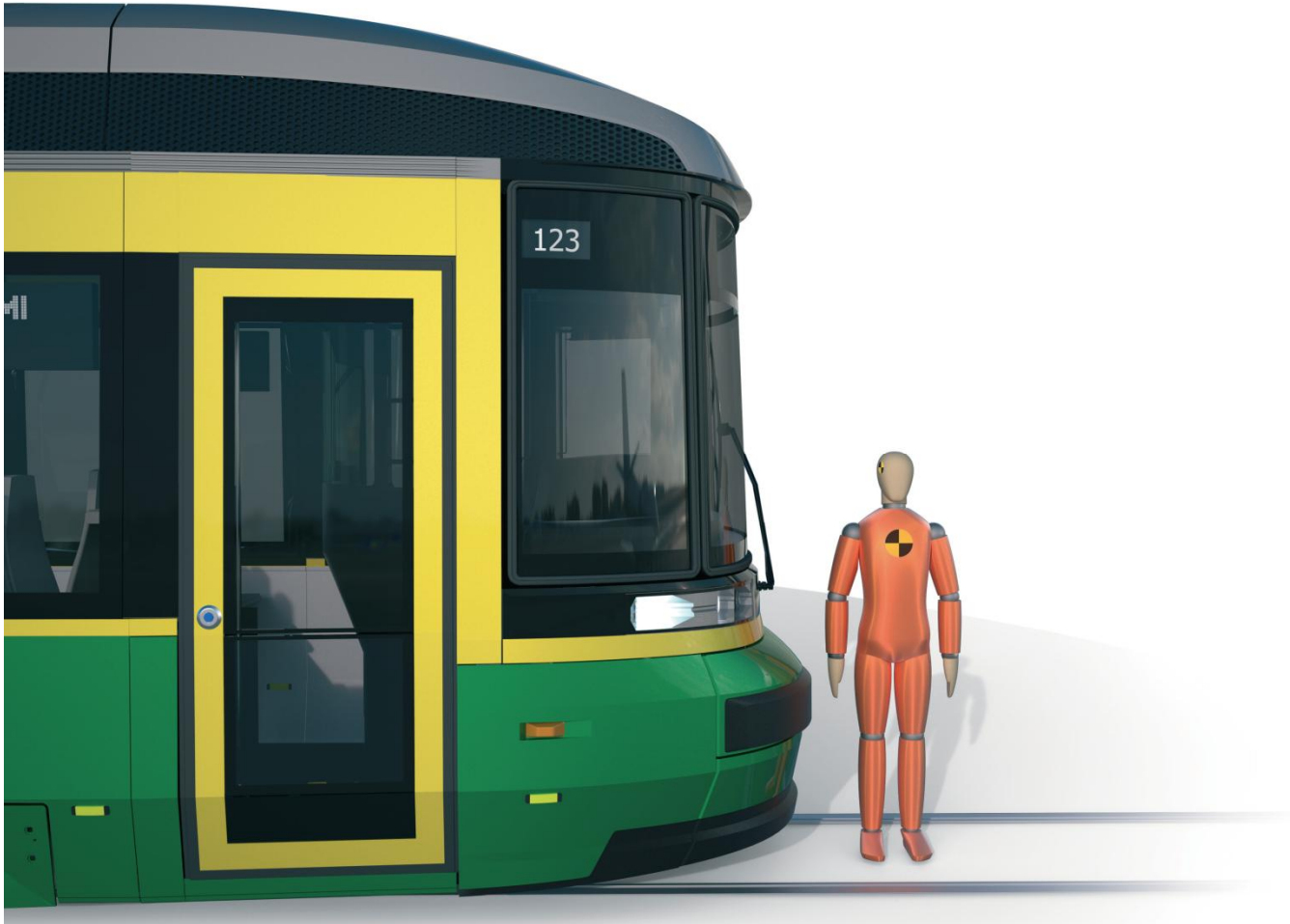

Transtech Artic - matkustusmukavuus



Transtech Artic - Helsingin uusi raitiovaunu



facebook



 1 071

stadtverkehr

Fachzeitschrift für den öffentlichen Personen-Nahverkehr auf Schiene und Straße

Speziell für die HKL/HST, Helsinki, entwickelt

Artic: Helsinkis neue Straßenbahn

von Dr.-Ing. E.h. Harry Hondius, Dipl.-Ing. ETHZ, Beaufays, Belgien

yle UUTISET

Helsinki 12.8.2013 klo 18:12 | päivitetty 12.8.2013 klo 18:12

Matkustajille koekyyti kelpasi - uusi spora on ripeä ja hiljainen

 MTV3.fi

Kolina on historiaa - uusi ratikka kerää kehuja

HELSINGIN UUTISET

Uusi ratikka kulkee hiljaa keinuen

Transtech Artic – tarina jatkuu...

